

Section 2000 Index

CIRCULATING OIL SYSTEMS.....50



Versatile type of lubrication, providing a continuous flow of liquid, etc.

CUSTOM LUBRICATION SYSTEMS FORM51



Ordering information for circulating systems. Included on the form is information about lubricant, pump dispenser type, heat exchanger and environment, etc.

BULLS-EYE SIGHT FEED VALVES - UNIVERSAL PATTERN52



Allows for visual observation of the liquid stream from a distance, with the volume of flow controlled by an adjustable needle valve.

CONSTANT FLOW CONTROL VALVES.....52



These are used in low pressure lubricating systems.

ACCESSORIES52-53

LIQUID FILTERS.....53



These types of liquid filter have a 40 micron filter that can be cleaned or replacement with ease.

REFERENCE DRAWING - BASIC PUMP53

VENT PLUGS WITH FILTER53



Use of these vent plugs help relieve pressure or vacuum.

WINDOW FLOW SIGHTS FOR FULL FLOW53



Primarily these are used in low pressure oil lines. They have no restriction on the inside.

Circulating Lubrication Systems

CIRCULATING OIL SYSTEMS are the most versatile type of lubrication system available. They are often used on large expensive bearings, or when it is absolutely essential to provide continuous operation under adverse conditions.

A typical pump dispenser which provides a continuous flow of liquid to the bearings is shown. By proper direction of liquid flow, this system can be used for heavily loaded bearings operating at high speeds and temperatures. This type of system is good in extremely dirty and corrosive atmospheres. The liquid is normally returned to the pump dispenser by gravity. Adequately sized return lines are necessary with vents to provide a free flow of return liquid back to the reservoir. Any restricted flow at this point could cause high liquid level in the bearing housing, creating heat, and damaging the bearings. Flow sights are often used to monitor the return liquid flow. There are

also a wide variety of sight feed valves and control valves available to adjust and regulate the liquid flow into the bearing.

Several of the common options available for the pump dispensers are dual pumps for a back up system, dual filters available in micron ratings down to 5 microns, heat exchangers, either air cooled or water cooled, permitting heat removal rates extending into the hundreds of thousands of BTU/HR. Heaters can also be provided to maintain a certain liquid temperature, and can be utilized for cold weather start ups. Pressure regulating devices, along with pressure switches, low level switches, and filter condition alarms are also available.

These systems can be found as simple off the shelf devices or can be specifically designed and engineered to actual customer needs.

SPECIFICATIONS:

- Tank Removable Top Cover for Cleaning
- Operating Temperature 225° F. Max.
- Viscosity 750 S.S.U. Max.
- By-Pass Adjustable Set at 35 P.S.I.
- Line Filter Self-Cleaning 88 Micron
- Suction Filter 100 Mesh
- Tank Welded Steel
- Pump Cast Iron
- Piping Iron
- Check Valve Brass

When Ordering Specify:

- Model Number
- Fill in information on next page.

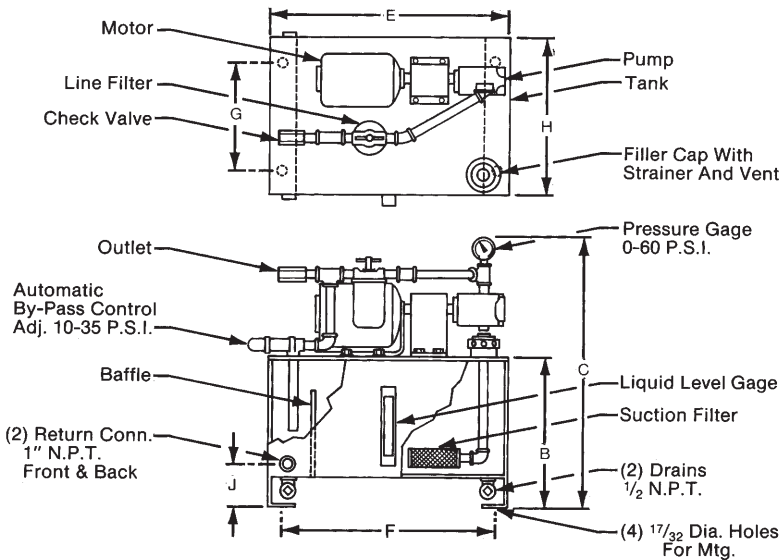

CUSTOM DESIGNED

Model Number	G.P.M.	Capacity	Open Motor				Outlet N.P.T.	B	C	E	F	G	H	J
			H.P.	Volts & Frequency	R.P.M.	Phase								
B-1473-1	1	5 GAL.	1/4	115V. 60 Hz.	1750	1	1/4	11 1/2	21 1/2	16	14 1/4	7	10	4
B-1474-1	2	10 GAL.	1/3	115V. 60 Hz.	1750	1	3/8	15	30	20	18 3/4	9	12	5
B-1475-1	3	10 GAL.	1/3	115V. 60 Hz.	1750	1	1/2	15	25	20	18 3/4	9	12	5
B-1476-1	4	15 GAL.	1/2	115V. 60 Hz.	1750	1	1/2	15	26	24	21 3/4	12 3/4	15	4 1/2
B-1477-1	5	15 GAL.	1	230/460V. 60 Hz.	1750	3	3/4	15	37	24	21 3/4	12 3/4	15	4 1/2
B-1478-1	9	30 GAL.	2	230/460V. 60 Hz.	1750	3	3/4	27	43	24	21 3/4	12 3/4	15	4 1/2
B-1479-1	11	30 GAL.	3	230/460V. 60 Hz.	1750	3	3/4	27	43	24	21 3/4	12 3/4	15	4 1/2

* Special - Please Consult Factory

Circulating Lubrication System Specifications Sheet

COMPANY:			DATE:		
ADDRESS:					
CITY:		STATE:		ZIP:	
CONTACT PERSON:			PHONE:		
FAX:			E-MAIL:		
DATE DUE:					

LUBRICANT INFORMATION

LIQUID TYPE AND NAME:	VISCOSITY @ 100° F. SSU:
GALLONS PER MINUTE:	SYSTEM PRESSURE:
FILTRATION REQUIREMENTS- 88 MICRONS STANDARD:	

PUMP DISPENSER INFORMATION

RESERVOIR CAPACITY (GAL.):	MOTOR TYPE		
TEMPERATURE GAGE YES <input type="checkbox"/> NO <input type="checkbox"/>	OPEN/DRIP PROOF <input type="checkbox"/>	EXP. PROOF <input type="checkbox"/>	TENV/TEFC <input type="checkbox"/>
TEMPERATURE SWITCH YES <input type="checkbox"/> NO <input type="checkbox"/>	OTHER SPECIFICATIONS:		
PRESSURE SWITCH YES <input type="checkbox"/> NO <input type="checkbox"/>	AVAILABLE CURRENT		
LOW LEVEL SWITCH YES <input type="checkbox"/> NO <input type="checkbox"/>	VOLTAGE	FREQUENCY	PHASE
FLOW SWITCH YES <input type="checkbox"/> NO <input type="checkbox"/>			
NEEDLE VALVES YES <input type="checkbox"/> NO <input type="checkbox"/>			
DIFFERENTIAL PRESSURE SWITCH ACROSS FILTER(S)	YES <input type="checkbox"/>	NO <input type="checkbox"/>	
DIFFERENTIAL PRESSURE GAGE(S) ACROSS FILTER(S)	YES <input type="checkbox"/>	NO <input type="checkbox"/>	
PUMP/MOTOR: SINGLE <input type="checkbox"/> DUAL <input type="checkbox"/>	SPECIAL:		
LINE FILTER: SINGLE <input type="checkbox"/> DUAL <input type="checkbox"/>			
HEAT EXCHANGER: SINGLE <input type="checkbox"/> DUAL <input type="checkbox"/>			

HEAT EXCHANGER INFORMATION

HEAT EXCHANGER TO REMOVE:		B.T.U.'s/HOUR					
WATER COOLED					AIR COOLED		
° F-LIQUID IN	° F-LIQUID OUT	° F - H ₂ O MAX.	H ₂ O PSI	H ₂ O GPM	° F-LIQUID IN	° F-LIQUID OUT	° F - AIR MAX
TEMPERATURE CONTROLS:		AUTOMATIC <input type="checkbox"/>	MANUAL <input type="checkbox"/>	FURNISHED BY CUSTOMER <input type="checkbox"/>			

IMMERSION HEATER INFORMATION

MIN. LIQUID TEMP	OPER. LIQUID TEMP	HEAT UP TIME	WATTS	VOLTAGE & FREQUENCY
TEMPERATURE CONTROLS:		AUTOMATIC <input type="checkbox"/>	MANUAL <input type="checkbox"/>	FURNISHED BY CUSTOMER <input type="checkbox"/>

INSTALLATION ENVIRONMENT INFORMATION

INDOOR <input type="checkbox"/>	AMBIENT TEMP.	ALTITUDE	NOTE ALL SIZE LIMITATIONS
OUTDOOR <input type="checkbox"/>			

DESCRIPTION OF EQUIPMENT TO BE LUBRICATED, INCLUDING NO. POINTS AND ELEVATIONS AND RETURN LINE ELEVATION.

Accessories

UNIVERSAL PATTERN BULLS-EYE SIGHT FEED VALVES

allow visual observation of the liquid stream from a distance, with the volume of flow controlled by an adjustable needle valve. The Bulls-Eye sight feed valve has excellent flow characteristics with low pressure drop.

These units are principally used on gravity or pressure oiling systems of larger machinery for lubrication where considerable capacities of liquid must be dispensed.

Large sight glass windows on both sides of the valve can easily be removed for cleaning or replacement without disconnecting the valve. Threaded retaining rings on both sides secure the glass with full circumferential support for excellent sight pressure integrity.

SPECIFICATIONS:

- Pressure 125 P.S.I. Inlet to Orifice 55 P.S.I. Sight Chamber Max. with Vent Sealed
- Temperature 225° F. Maximum
- Valve Body Aluminum Alloy
- Needle Ass'y Steel, Plated
- Sight Glass 1½ Dia.
- Seals Buna-N
- Port 1/4 I.D.

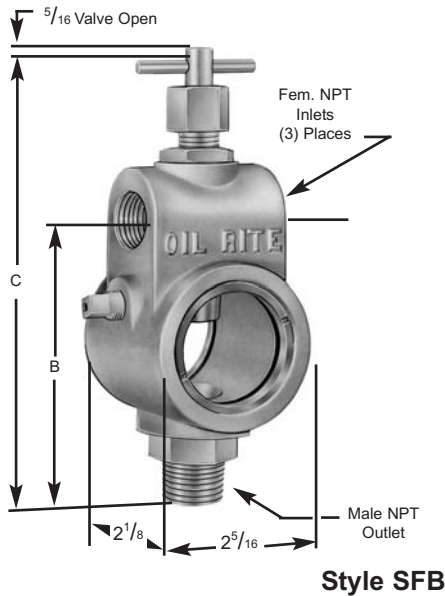

Style SFB

When Ordering Specify:

- Catalog Number

Catalog Number	Body Style	Inlet N.P.T.	Outlet N.P.T.	B	C
B-2501-1	T-Handle	1/4	1/4	4	6 ¹¹ / ₃₂
B-2501-2		3/8	3/8		
B-2501-3		1/2	1/2		
B-2501-4		1/2	3/4		
B-2501-5	Tamper-proof	1/4	1/4	4	6 ¹¹ / ₃₂
B-2501-6		3/8	3/8		
B-2501-7		1/2	1/2		
B-2501-8		1/2	3/4		

CONSTANT FLOW CONTROL VALVES are used in low pressure lubricating systems. They do not require frequent adjustment usually needed on ordinary valves.

They have a fixed flow rate and can be equipped with orifices producing a specific flow rate ranging from ounces per minute to gallon per minute. The flow rate selected will remain constant within plus or minus 20% for 3 to 9 ounces per minute, and within plus or minus 10% for 1 pint to 1 gallon per minute. This accuracy will be retained with varying pressures, ranging from 15 PSI minimum to 125 PSI maximum, and with any oil having a viscosity of 400 SSU minimum to 750 SSU maximum.

SPECIFICATIONS:

- Flow Rate Non Adjustable (See Table)
- Pressure 15 P.S.I. Min. 125 P.S.I. Max.
- Oil Viscosity Between 400 and 750 S.S.U.
- Temperature 225° F. Maximum
- Valve Body Aluminum Alloy
- Seals Buna-N
- Piston Brass

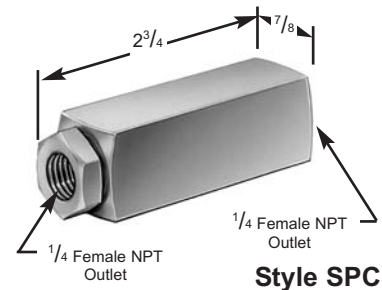

Style SPC

When Ordering Specify:

- Catalog Number

Catalog Number	Flow Rate Per Min.	Flow Tolerance	Orifice Size
* B-1844-1	3 OZ.	± 20%	.024
* B-1844-2	6 OZ.		.033
* B-1844-3	9 OZ.		.038
* B-1844-4	1 PT.	± 10%	.047
* B-1844-5	1QT.		.067
* B-1844-6	1/2 GAL.		.093
* B-1844-7	3/4 GAL.		.106
* B-1844-9	1 GAL.		.111

* Special - Please Consult Factory

Accessories cont.

WINDOW FLOW SIGHTS FOR FULL FLOW are primarily used in low pressure oil lines. There are no restrictions on the inside, therefore, no pressure drop, resulting in the full flow of liquid equal to respective pipe size. They can be installed in any position, either horizontally, vertically, or at an angle, and are offered in various pipe sizes.

SPECIFICATIONS:

- Pressure 125 P.S.I. Maximum
- Temperature 225° F. Maximum
- Sight Glass Pressure Tight Solid Gaskets
- Body Steel, Plated
- Seals Buna-N



When Ordering Specify:

- Catalog Number

Catalog Number	N.P.T.	A	B	C	D	K Hex
A-715-1	1/8 Fem.	11/32	1 1/16	2 1/4	9/16	13/16
A-715-2	1/4 Fem.	7/16	1 1/16	2 1/4	9/16	13/16
A-711-2	3/8 Fem.	37/64	1 3/8	2 7/8	3/4	15/16
A-733-2	1/2 Fem.	45/64	1 3/8	3 5/8	7/8	1 1/16
A-2109-1	3/4 Fem.	59/64	1 1/2	3 51/64	15/16	1 1/4

VENT PLUGS WITH FILTER can be used to relieve pressure or vacuum. These vent plugs assure pressure equalization and minimize undesirable problems, such as bearing seal blowout due to excessive pressure.

The vent plugs allow air to freely communicate through a 40 micron filter. The filter is easy to clean—just unscrew the hex cap on top, remove filter element, clean and reassemble.

SPECIFICATIONS:

- Temperature 225° F. Maximum
- Body Steel, Plated
- Filter 40 Micron

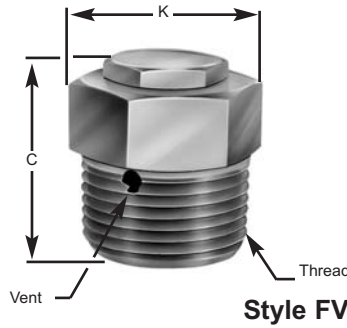

When Ordering Specify:

- Catalog Number

Catalog Number	Thread Size	C	K Hex
A-3432-1	1/8 Male N.P.T.	1	1 1/16
A-3432-2	1/4 Male N.P.T.	1	1 1/16
A-3432-3	3/8 Male N.P.T.	1 1/16	3/4
A-3432-4	1/2 Male N.P.T.	1 3/16	15/16
A-3432-5	3/4 Male N.P.T.	1 1/4	1 1/16

LIQUID FILTERS have a 40 micron filter element that can be easily removed for occasional cleaning or for the replacement of the element itself.

An idea of the capacity of the filter can be visualized from a test of 750 SSU liquid at 70° F. gravity feed with a 6 inch head. This resulted in a flow of 1/2 ounce per minute. The maximum pressure of the unit should not exceed 125 P.S.I.

SPECIFICATIONS:

- Pressure 125 P.S.I. Maximum
- Flow Capacity 1/8 G.P.M. at 10 P.S.I. with S.A.E. 20 Oil
- Temperature 225° F. Maximum
- Body Aluminum
- Filter 40 Micron
- Seals Buna-N

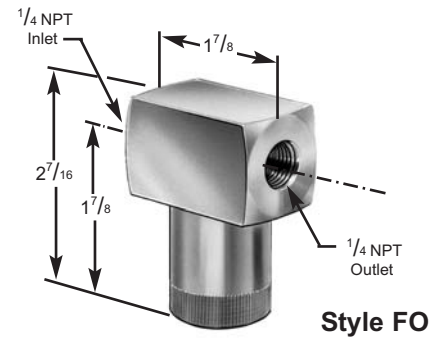

When Ordering Specify:

- Catalog Number

Catalog Number	Inlet N.P.T.	Outlet N.P.T.	Filter
A-4739-1	1/4 Fem.	1/4 Fem.	40 Micron

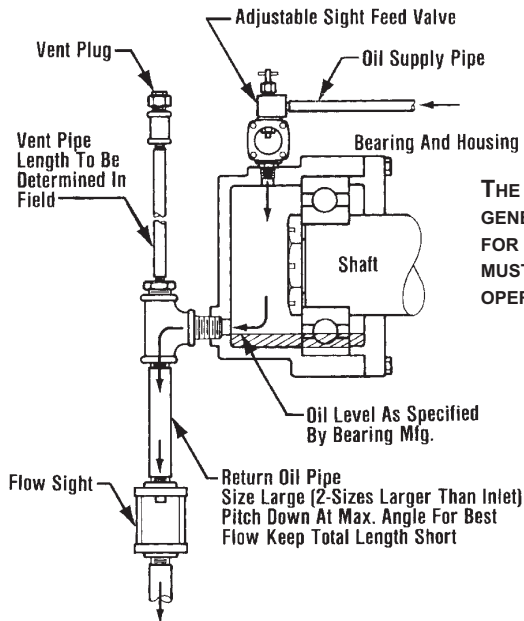

THE PURPOSE OF THESE DRAWINGS ARE FOR GENERAL REFERENCE ONLY. FINAL DESIGN FOR A CIRCULATING LUBRICATION SYSTEM MUST BE DETERMINED BY ACTUAL FIELD AND OPERATING CONDITIONS.

