

# Section 3000

## AIR OPERATED SPRAY DISPENSERS - CENTRAL ACRYLIC RESERVOIR .....36



Versatile type of lubrication able to feed liquid to elevated, distant or inaccessible points.

## AIR OPERATED SPRAY DISPENSERS - CENTRAL STEEL RESERVOIR .....37



Centralized steel reservoir which dispenses liquid through one or more nozzles permitting a fine or coarse spray from any angle.

## AIR OPERATED DISPENSERS - DELUXE AIR PRESSURIZED RESERVOIR .....38



Simple operation in compact design with air pressurized reservoir, feeding liquid to elevated, distant, or inaccessible points.

## CHAIN LUBRICATION SCHEMATIC ....39

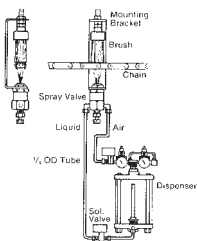

Allows for visual observation of the liquid stream from a controlled adjustable needle valve.

## CONVEYOR CHAIN LUBRICATION SCHEMATIC .....39

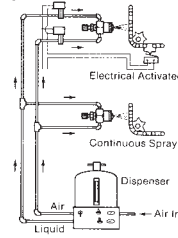

Shows guide for general use only.

## CYLINDER LUBRICATION SCHEMATIC .....39

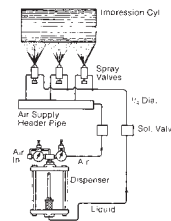

Shows guide for general use only.

## HELPFUL SUGGESTIONS FOR REDUCING FOGGING AND ATMOSPHERIC CONTAMINATION .....39

## PATTERN AND CAPACITY CHART .....39

## PREVENTION OF AFTER - DRIP INSTRUCTIONS .....39

## SPRAY VALVES - OPERATING INSTRUCTIONS .....39



Spray valves have excellent, dependable performance in a compact design and are offered in flat or round spray patterns.

# Spray System Dispensers

**AIR OPERATED SPRAY DISPENSERS** feed liquid to elevated, distant, or inaccessible points. The system consists of a central acrylic reservoir which dispenses liquid through one or more spray nozzles.

These lubricators can be used to apply liquid to conveyors, chain drives, bull gears, trolley wheel bearings, wire rope, strip stock for punch presses, or any other application requiring a film of liquid. The amount of liquid sprayed is infinitely adjustable from a fine spray, invisible to the eye, to a coarse spray by adjusting the air pressure of the needle valve on the spray nozzle. Any liquid that flows can usually be sprayed, up to 1000 SSU viscosity at 100° F. The lighter the liquid, the easier it is to spray.

Operation is simple. A normal air line of approximately 80 PSI is connected to a pressure regulator which reduces the pressure within the reservoir to any desired amount. This adjustable, reduced air pressure forces the liquid through piping to separate control valves for dispensing or spraying. Smooth control of liquid flow can be effected by pressure regulation and separate control valves, a desirable feature for conditions demanding fine adjustment.

For best performance, a second regulator with suitable air capacity is supplied to adjust the air pressure to spray valves. Operation can be made automatic with two solenoid valves which can be activated by a motor drive or with a timer.

This allows the valves to continually or momentarily apply a film of liquid. A relief valve makes operation safe.

**SPECIFICATIONS:**

- Pressure 30 P.S.I. Maximum
- Temperature 160° F. Maximum
- Air Capacity 5 C.F.M. at 20 P.S.I.
- Liquid Capacity 3 G.P. H. at 10 P.S.I.
- Components External Mounted
- Max. Spray Valves 4 (Order from **Page 39**)
- Reservoir Clear Acrylic
- Seals Buna-N
- Covers Aluminum Alloy



**When Ordering Specify:**  
• Catalog Number

Catalog Number	Capacity	C
* B-1267-1	1 QT.	8 <sup>3</sup> / <sub>4</sub>
* B-1267-2	1/2 GAL.	12 <sup>1</sup> / <sub>4</sub>
* B-1267-3	1 GAL.	17 <sup>1</sup> / <sub>4</sub>
* B-1267-4	2 GAL.	30 <sup>1</sup> / <sub>4</sub>

\* Special - Please consult Factory

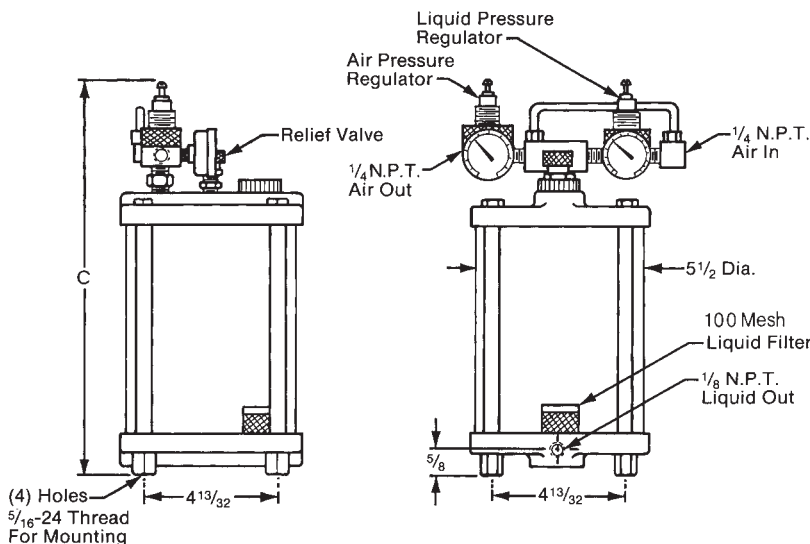

# Spray System Dispensers

## AIR OPERATED SPRAY DISPENSERS

permit fine or coarse spraying of liquids from any angle. The system consists principally of a central steel reservoir which dispenses liquid through one or more spray nozzles.

This spray system can be used to apply liquid to conveyors, chain drives, bull gears, trolley wheel bearings, wire rope, strip stock for punch presses, or any other application requiring a film of liquid. The amount of liquid sprayed is infinitely adjustable from a fine spray, invisible to the eye, to a coarse spray, by adjusting the air and liquid pressure or the needle valve on the spray nozzle. Any liquid that flows can usually be sprayed, up to 1000 SSU viscosity at 100° F. The lighter the

liquid, the easier it is to spray.

Operation is simple. An air line at approximately 80 PSI is connected to a regulator which reduces the air pressure within the reservoir to a desired amount. This reduced air pressure forces liquid through tubing to individual or gang-mounted spray nozzles each having a precision needle valve adjustment. Smooth, hairline adjustments can be made and any setting retained.

An additional regulator on the central reservoir for air pressure allows further control. Air filters are available as an option. Liquid filters and pressure relief valves are also provided.

For automatic operation, solenoid shut-off valves are available. The solenoid

valves permit continuous or momentary spray application of a liquid film. This is done by either wiring the solenoid valves across the line of a drive motor to turn on and off the system automatically with the drive or a timer can be used.

## SPECIFICATIONS:

- Pressure 30 P.S.I. Maximum
- Temperature 225° F. Maximum
- Air Capacity 5 C.F.M. at 20 P.S.I.
- Liquid Capacity 3 G.P.H. at 10 P.S.I.
- Components External Mounted
- Max. Spray Valves 4 (Order from **Page 39**)
- Reservoir Steel, Painted
- Seals Buna-N

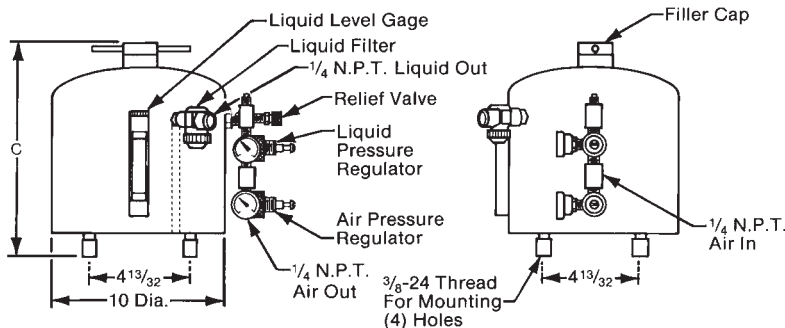
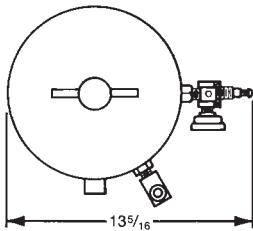

## When Ordering Specify:

- Catalog Number

Catalog Number	Capacity	C
* B-1266-3	2 1/2 GAL.	12 1/2
* B-1266-4	5 GAL.	20 1/2

\* Special - Please consult Factory

# Spray System Dispensers

**DELUXE AIR OPERATED DISPENSERS** offer a compact design, extreme reliability, with built in components. The air pressurized reservoir feeds liquid to elevated, distant, or inaccessible points. These systems are ideal for use on applications where gravity feeding is not suitable. This unit is exceptionally desirable for dusty and dirty surroundings, since the pressure within the reservoir prevents foreign matter from contaminating liquid or clogging valves.

Operation is simple. A normal air line at approximately 80 PSI is connected to a pressure regulator which reduces the pressure within the steel reservoir to any desired amount. This adjustable reduced air pressure forces the liquid through piping to control valves for dispensing or spraying. Very fine adjustments of liquid flow can be achieved by air pressure regulation and control valves.

For best performance, a second pressure regulator with suitable capacity is supplied for use on spray systems in order to precisely adjust the air volume to spray valves. Operation can be made

automatic with the use of two solenoid valves. Stopping and starting is accomplished by wiring across a motor drive or by using a timer. A dump valve is provided to bleed the air from the reservoir before filling. A relief valve set for 30 PSI makes operation safe.

The reservoir of either 2½ gal. or 5 gal. capacity is bolted to the lower base which houses all components with only flush mounted level gage and control handles exposed. Air filters and liquid filters can readily be serviced for cleaning. The dispenser can be either floor mounted or wall mounted. Wall mounting requires an optional wall bracket which can be provided.

The steel dispenser is designed to serve as a central reservoir for oiling systems. It is furnished with an oil filter, pressure regulator with gage, relief valve, liquid level gage, and a filler cap for replenishing the oil supply.

These lubricators can be used to apply liquid to conveyors, chain drives, bull gears, trolley wheel bearings, wire rope, strip stock for punch presses, or any other

application requiring a film or liquid. The amount of oil sprayed is infinitely adjustable from a fine spray, invisible to the eye, to a coarse spray by adjusting the air pressure or the needle valve on the spray nozzle. Any liquid that flows can be sprayed up to 1000 SSU viscosity at 100° F. The lighter the liquid, the easier it is to spray.

**SPECIFICATIONS:**

- Pressure 30 P.S.I. Maximum
- Temperature 225° F. Maximum without Solenoids  
180° Max. for AC  
150° Max. for DC
- Air Capacity 30 C.F.M. Maximum @ 20 P.S.I.
- Liquid Capacity 3 G.P.H. Maximum @ 10 P.S.I.
- Components Panel Mounted Within Unit
- Max. Spray Valves (B-2013 1-4)  
4 (Order from **Pg. 39**)
- Max. Spray Valves (B-2013 11-14)  
24 (Order from **Pg. 39**)
- Reservoir & Base Welded Steel, Painted

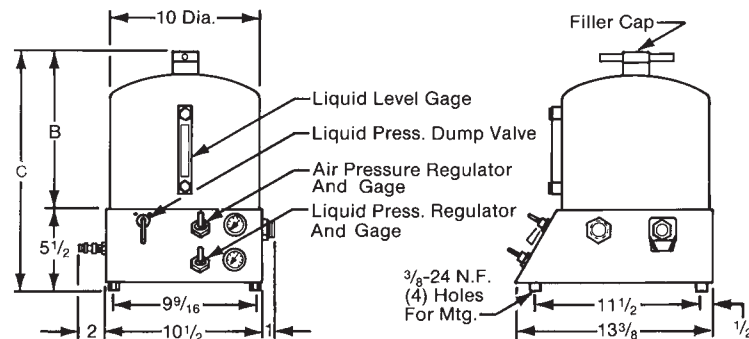
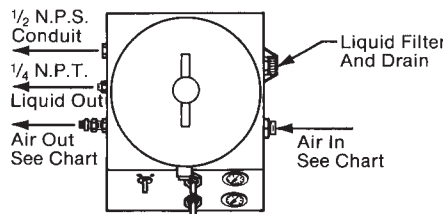

**When Ordering Specify:**

- Model Number
- Voltage and Frequency

Model Number	Solenoid Valve	Air in Air Out	Cap.	B	C
* B-2013-1	without	1/4	2 1/2 Gal	11 3/8	16 7/8
* B-2013-2		N.P.T.	5 Gal	19 3/8	24 7/8
* B-2013-3	with		2 1/2 Gal	11 3/8	16 7/8
* B-2013-4			5 Gal	19 3/8	24 7/8
* B-2013-11	without	1/2	2 1/2 Gal	11 3/8	16 7/8
* B-2013-12		N.P.T.	5 Gal	19 3/8	24 7/8
* B-2013-13	with		2 1/2 Gal	11 3/8	16 7/8
* B-2013-14			5 Gal	19 3/8	24 7/8

\* Special - Please consult Factory

# Spray Valves

**SPRAY VALVES** have excellent, dependable performance in a compact design and are offered in flat or round spray patterns. The spray valves minimize objectional fogging. Any liquid that flows, up to a viscosity of 1000 SSU at 100° F., can be sprayed.

The spray valves are used for a multitude of applications such as lubrication of chains, cables, gears, punches, dies, drills, taps, reamers, milling cutters, grinding wheels, sheet stock, die casting molds --- applying oil to food products, water to embossing rolls of paper machinery, etc. The amount of oil sprayed is infinitely adjustable from a fine spray, invisible to the eye, to a coarse spray to suit most applications.

Spray valves are provided with a liquid inlet, (1/8" female NPT). Each unit has an extra-fine needle valve to meter or shut off the flow of liquid with a knurled hand wheel.

Spray valves with a larger orifice are also available for very heavy oil, and for applications where large quantities are to be sprayed. Tamperproof construction is also available. Spray valves can be manifold mounted, if so desired.

**SPECIFICATIONS:**

- Liquid Pressure 5 P.S.I. Minimum  
20 P.S.I. Maximum
- Air Pressure 5 P.S.I. Minimum  
20 P.S.I. Maximum
- Temperature 225° F. Maximum
- Body Aluminum Alloy
- Seals Buna-N
- Needle Stainless Steel
- Nozzle Brass

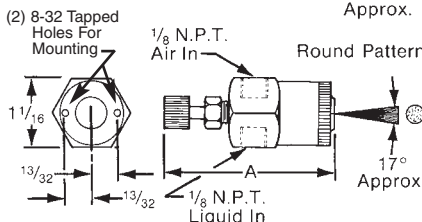
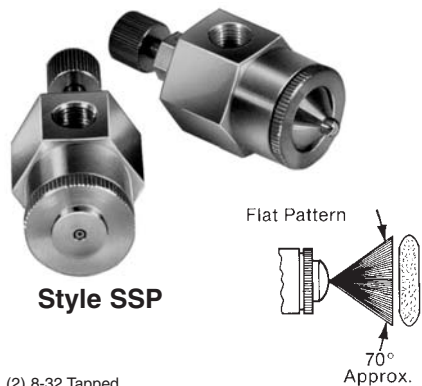

**When Ordering Specify:**

- Catalog Number

Catalog Number	Pattern	A	Type
A-2748-1	Round	2 <sup>11</sup> / <sub>16</sub>	Handwheel
A-3015-1	Flat	2 <sup>13</sup> / <sub>16</sub>	Handwheel
A-2748-2	Round	2 <sup>7</sup> / <sub>16</sub>	Tamperproof
A-3015-2	Flat	2 <sup>9</sup> / <sub>16</sub>	Tamperproof

**OPERATING INSTRUCTIONS FOR SPRAY VALVES**

- All spray Valves should be operated with air operated dispensers having dual-pressure control, one for liquid and one for air. For best performance, the liquid pressure should equal or exceed the air pressure.
- Use the needle valve for adjustment only. This adjustment is sensitive; as little as 1/4 turn either way may give desired results.
- Both liquid and air nozzles are readily removable for cleaning. They are machined to close limits, and the slightest change in shape, due to mishandling, may alter the spray pattern unacceptably.
- When making adjustment on tamperproof valves, use two wrenches so that the packing nut is not disturbed. If the packing nut is over-tightened, it could force the stem against the seat and damage it.

**PREVENTION OF AFTER-DRIP**

- To minimize drip after shut-off, an individual shut-off or check valve should be located in the liquid line close to the nozzle.
- Cycle liquid only and leave air on continuously.
- Leave air on longer than liquid to purge spray valve.
- Use piping as small as possible (1/8" OD Tube) for liquid leading to spray valves from solenoid valves.
- Locate solenoid valve as close as possible to spray valve.
- Make sure no air is in liquid line. This will act as an accumulator and force liquid through spray valves after solenoid valve is shut off.
- Hoses will also act as accumulator, expanding during pressure cycle and contracting during pressure off, thereby forcing excess liquid through spray valves.

**HELPFUL SUGGESTIONS FOR REDUCING FOGGING AND ATMOSPHERIC CONTAMINATION**

- Excessive air volume and /or air velocity.  
Remedy: Lower air pressure at spray valve to an absolute minimum.
- Nozzle too far from point of application, causing excessive air friction.  
Remedy: Move spray nozzle closer to point of application. As a result, two or more valves may be required to compensate for the smaller pattern.
- Air movement and air turbulence caused by the movement of the material being sprayed can deflect spray into the atmosphere.  
Remedy: Spray at an angle against material travel. Experiment to find best angle.

**PATTERN AND CAPACITY CHART GENERAL GUIDE ONLY**

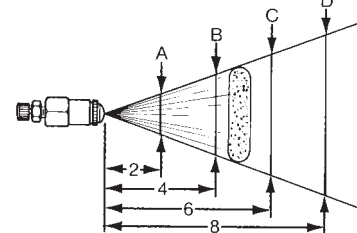

Liquid Capacity: 1 G.P.H. #20 Oil @ 40 P.S.I.  
Maximum Needle Valve Setting

Air Pressure	Air Capacity	Pattern Size			
		A	B	C	D
10 P.S.I.	.80 CFM	2 <sup>1</sup> / <sub>2</sub>	4 <sup>1</sup> / <sub>2</sub>	6 <sup>1</sup> / <sub>2</sub>	8 <sup>1</sup> / <sub>2</sub>
15 P.S.I.	1.00 CFM	3	6	7	9
20 P.S.I.	1.25 CFM	3 <sup>1</sup> / <sub>2</sub>	6 <sup>1</sup> / <sub>2</sub>	8 <sup>1</sup> / <sub>2</sub>	10 <sup>1</sup> / <sub>2</sub>
25 P.S.I.	1.50 CFM	4 <sup>1</sup> / <sub>2</sub>	7 <sup>1</sup> / <sub>2</sub>	10 <sup>1</sup> / <sub>2</sub>	12 <sup>1</sup> / <sub>2</sub>

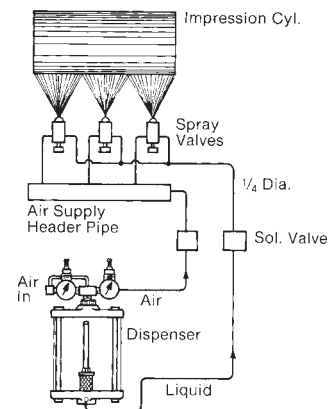

Size of Air Piping and Air Sol. Valve to be Determined by No. of Spray Valves Used.

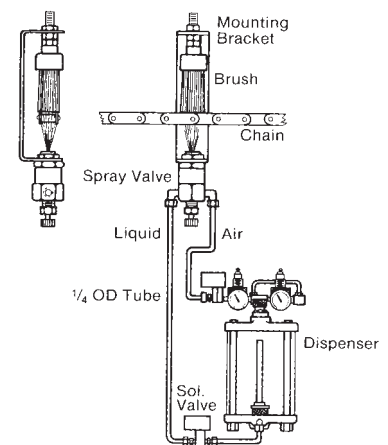

**Cylinder Lubrication**

